

POWER COMMANDER 6

Installation Guide for: PC6-15021

Model coverage: 2012-2015 Harley Davidson
Softail models with 103" / 110" Twin Cam

PARTS LIST



- | | | | |
|---|--------------------|---|------------------------|
| 1 | POWER COMMANDER 6 | 2 | POWER COMMANDER DECALS |
| 1 | INSTALLATION GUIDE | 2 | VELCRO STRIPS |
| 1 | USB CABLE | 1 | ALCOHOL SWAB |
| 2 | DYNOJET DECALS | 1 | EO FRAME LABEL |

**PLEASE READ ALL DIRECTIONS BEFORE STARTING INSTALLATION.
THE IGNITION MUST BE TURNED OFF BEFORE INSTALLATION.**



IPC6-15021.02

POWER COMMANDER 6

INPUT ACCESSORY GUIDE

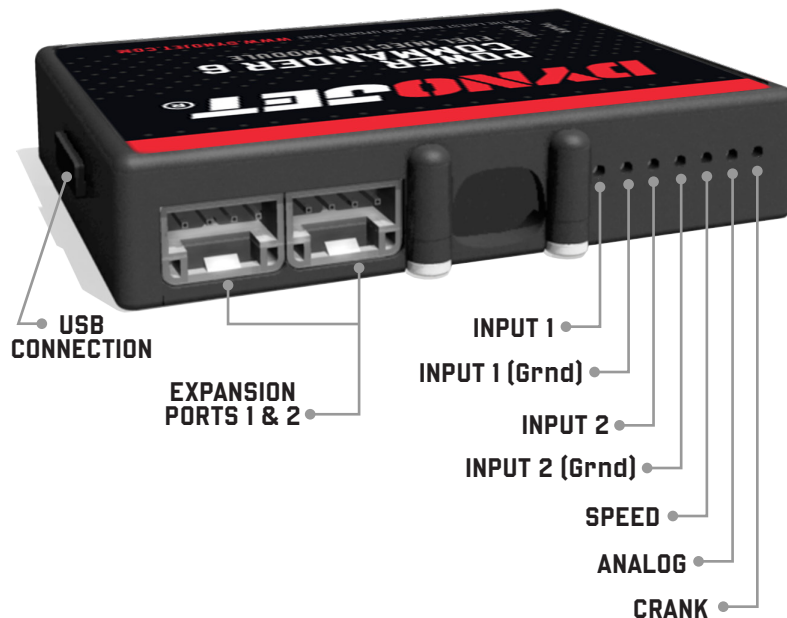

OPTIONAL ACCESSORY INPUTS

- Map** (Input 1 or 2) The PC6 has the ability to hold 2 different base maps. You can switch on the fly between these two base maps when you hook up a switch to the MAP inputs. You can use any open/close type switch. The polarity of the wires is not important.
- Shifter** (Input 1 or 2) Used for clutch-less full throttle upshifts. Insert the wires from the Dynojet quick shifter into either Input 1 or Input 2. The polarity of the wires is not important. Set to Input 2 by default.
- Speed** Not needed on Harley applications as the speed signal wire is built into the main wiring harness of the PC6.
- Analog** This input is for a 0-5v signal such as engine temp, boost, etc. Once this input is established you can alter your fuel curve based on this input in the Power Core software.
- Launch** You can connect a wire to either Input 1 or Input 2 and then the other end to a switch. This switch when engaged (continuity) will only allow the RPM to be raised to a certain limit (set in the software). When released, you will have full RPM.

WIRE CONNECTIONS

To input wires into the PC6 first remove the rubber plug on the backside of the unit and loosen the screw for the corresponding input. Using a 22-24 gauge wire, strip about 10mm from its end. Push the wire into the hole of the PC6 until it stops and then tighten the screw. Make sure to reinstall the rubber plug.

NOTE: If you tin the wires with solder it will make inserting them easier.

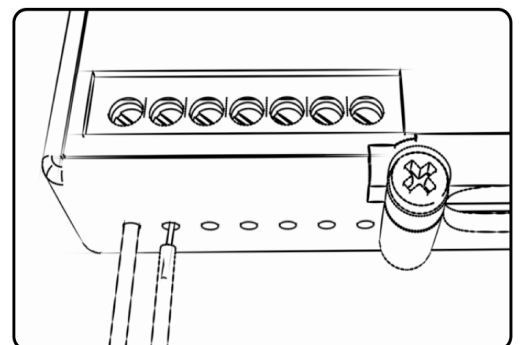

INSTALLING THE POWER COMMANDER 6

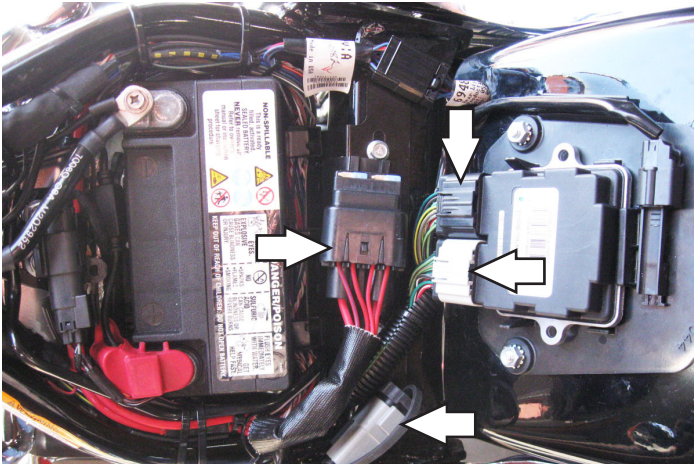

- 1 Remove the seat.
- 2 Unplug the stock wiring harness from the ECM.
- 3 Slide the fuse block off of its mounting tab.

Slide backwards to release.

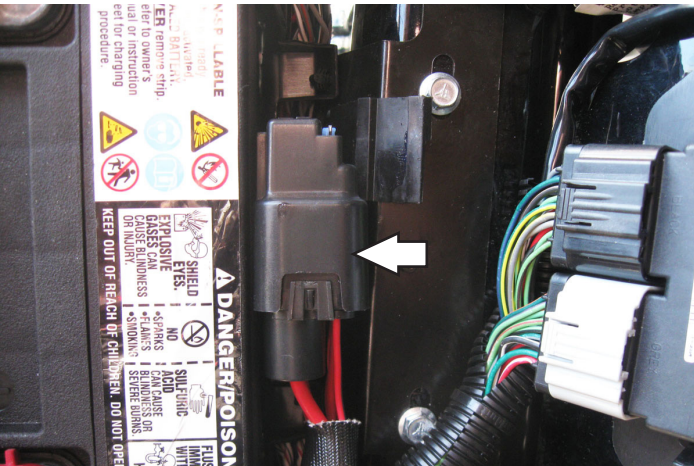

- 4 Position the fuse block so that it sits between the battery and frame.

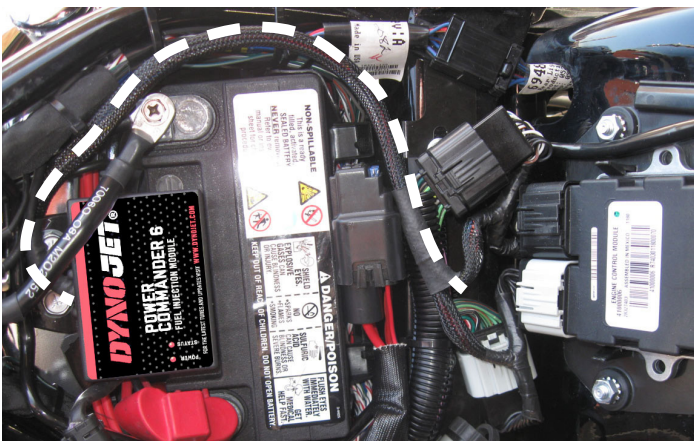

- 5 Install the PC6 in the cutout of the battery and route the harness to the right side of the battery.

Remove the negative battery lead so that you can route the PC6 harness underneath it.

6 Connect the PC6 in-line of the stock wiring harness and stock ECM.

Keep the connectors laying as flat as possible.

7 Reinstall the seat.

8 Affix the supplied CARB E.O label to a conspicuous area. The best location is next to the stock emissions label. Make sure to clean the surface before attaching.

Download the latest map files from our web site at dynojet.com/tunes.

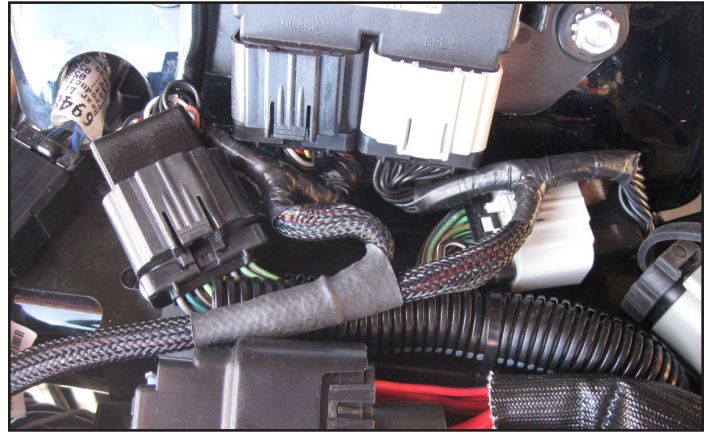



TRUTH IN PERFORMANCE

2191 MENDENHALL DRIVE, NORTH LAS VEGAS, NV 89081 - 800-992-4993 - DYNOJET.COM
© 2012-2022 DYNOJET RESEARCH ALL RIGHTS RESERVED